

3rd ANGLE PROJECTION

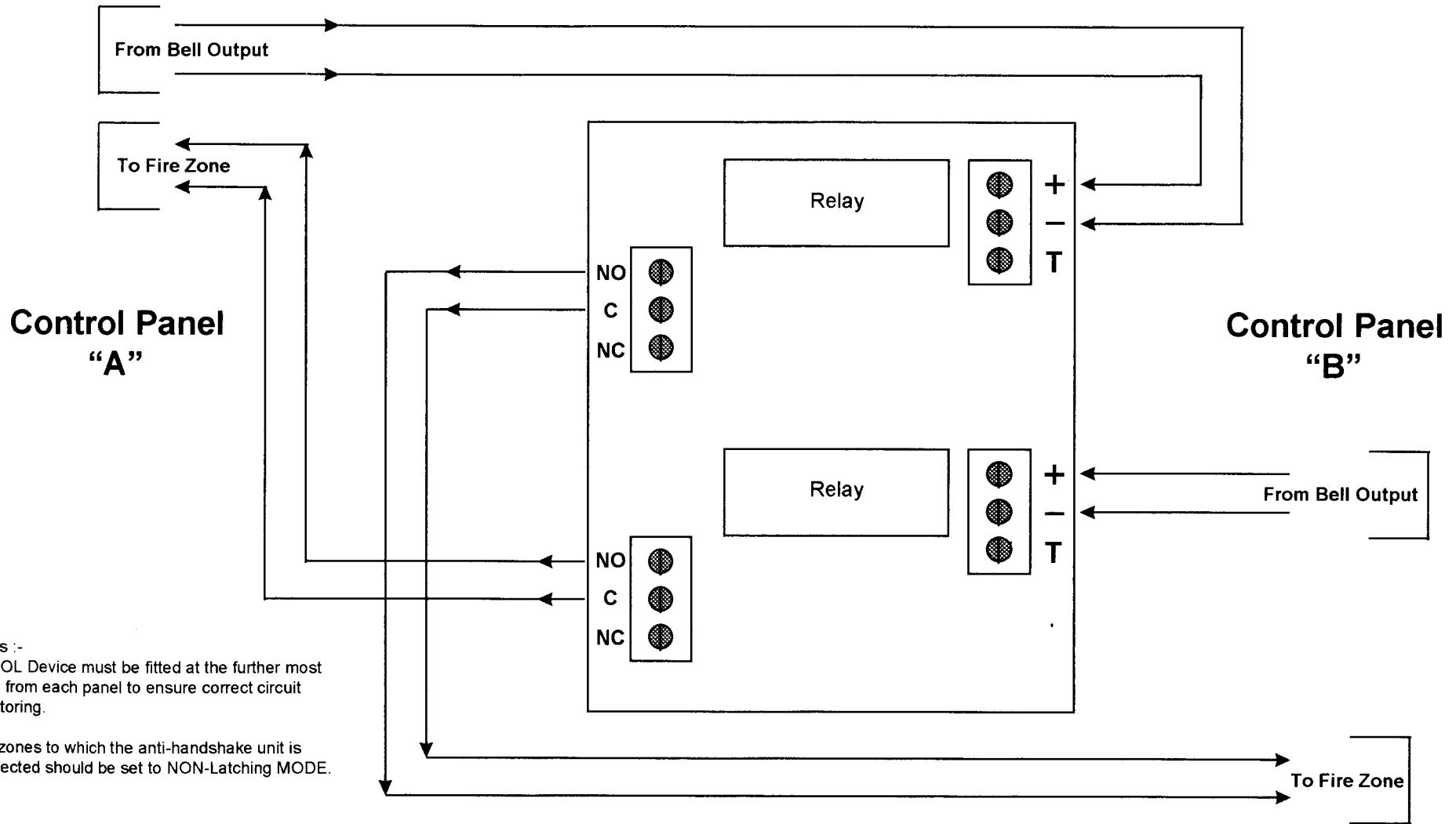
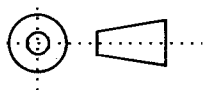

Notes :-
An EOL Device must be fitted at the further most point from each panel to ensure correct circuit monitoring.

Fire zones to which the anti-handshake unit is connected should be set to NON-Latching MODE.

DRAWN				MATERIAL	TOLERANCES	SCALE	TITLE	SECURITY CLASSIFICATION
RJW					0.0 +/- 0.2mm 1 DEC 0.00 +/- 0.02mm 2 DEC		Anti-Handshake Unit Connection Details	
CHECKED								DRAWING NUMBER
RJW	A	04 / 03		FINISH				
APPROVED	ISSUE	DATE	APP		UNLESS OTHERWISE STATED	ALL DIMENSIONS IN MILLIMETRES NON ACCUMULATIVE TOLERANCES	Nebula PPS Ltd. Unit 21 Winston Business Centre, Lancing W Sussex, BN15 8TU	SHEET NUMBER
RJW								