



NITTAN

ST-P SENSORTEC
PHOTOELECTRIC SMOKE DETECTOR
INSTRUCTION MANUAL

No: **NISM/STP/01**

DATE: **SEPTEMBER 1995**

PAGE: **1 of 7**

ISSUE: **01**

*From world leaders in **SENSOR TECHNOLOGY**
comes **SENSORTEC**.....*



*The new **ST-I** Ionisation and **ST-P** Photoelectric Smoke Detectors form part of a brand new range of fire detectors from Nittan (UK) Ltd called **SENSORTEC**.*

*The **ST-I** and **ST-P** are low cost, elegantly designed, low profile detectors which are aesthetically pleasing, thus enabling them to blend unobtrusively into modern working environments.*

*The **ST-I** and **ST-P** feature the very latest technological advancements such as ASIC design, increasing reliability and performance.*

*The **ST-I** and **ST-P** are compatible with other existing conventional fire detection systems.*

*A new **STB-4** range of bases has been introduced to work with the **SENSORTEC** products, however the **ST-I** and **ST-P** are also compatible with our previous RB-3/6 type base range.*

SENSORTEC.....



NITTAN (UK) LTD - BRINGING STYLE INTO FIRE DETECTION SYSTEMS



NITTAN

ST-P SENSORTEC
PHOTOELECTRIC SMOKE DETECTOR
INSTRUCTION MANUAL

No: NISM/STP/01	
DATE: SEPTEMBER 1995	
PAGE: 2 of 7	ISSUE: 01

CONTENTS:-

Section 1 - Introduction - Page 1

Section 2 - Operation - Page 2

Section 3 - Detector Models - Page 3

Section 4 - Base Models - Page 3

Section 5 - Installation - Page 3

Section 6 - Maintenance & Cleaning - Page 4

Section 7 - Specifications - Page 6

Section 8 - Environmental Parameters:- - Page 6
 - Temperature - Page 6
 - Humidity - Page 6

Section 9 - EMC - Page 6

Section 10 - Connections - Page 7

Section 11 - Dimensions - Page 7

Section 1 - INTRODUCTION

The ST-P is an attractively-styled, low cost, low profile photoelectric smoke detector for use in conventional fire detection systems. This detector is virtually identical in function to our 2KH-4T detector and can therefore be used as a direct replacement.

The ST-P has a chemically etched, stainless steel insect screen therefore reducing the ingress of insects and airborne contaminants.

The sensitivity of the ST-P is easily confirmed in the field, using the NID-ET5 electronic tester.

ST-P features:

- * **Optical detector, detecting visible particles of combustion**
- * **Low profile, stylish appearance**
- * **Supplied with red protective dust cover, (remove during commissioning)**
- * **Non-polarised terminals**
- * **Unauthorised head removal signal facility**
- * **Low monitoring current**
- * **Integral LED fire alarm indicator**
- * **Remote indicator output on standard 4T model**
- * **Easy to disassemble and reassemble for cleaning**
- * **Compatible with RB-3/RB-6 Bases**



LPCB REF: 041c/06
 ST-P
 and
 LPCB REF: 367a/02
 ST-P



**NITTAN**

ST-P SENSORTEC

PHOTOELECTRIC SMOKE DETECTOR

INSTRUCTION MANUAL

No: NISM/STP/01	
DATE: SEPTEMBER 1995	
PAGE: 3 of 7	ISSUE: 01

Section 2 - ST-P OPERATION

The smoke chamber of the ST-P is constructed so that light cannot enter from outside, but smoke can pass through the chamber slots. The ST-P utilises the light scatter sensing principle, the LED pulses every 8 seconds to maintain a low monitoring current. A quick charge time, (20 seconds), is also achieved. The detector incorporates an alarm verification function which requires two successive pulses before an alarm is given.

The interval between the first and second pulse is automatically reduced, to two seconds, after the first alarm level is monitored. The detector design provides strong immunity to air velocities, contamination and RF interference.

The geometry of the smoke chamber and optic's support assembly is designed to give the best possible signal to noise ratio, resulting in excellent response characteristics.

Section 3 - DETECTOR MODELS

The ST-P photoelectric smoke detector is supplied, as standard, with four terminals.

The ST-P has the facility to activate a remote LED indicator or auxiliary function, as standard.

The terminals on the ST-P detector head are configured as follows:-

Terminal 3 = zone positive in/out

Terminal 1 = zone negative in

Terminal 6 = zone negative out

Terminal 5 = 100 mA @ 24V d.c. switched output

Section 4 - BASE MODELS

A variety of bases are available for use with the ST-P detector. It is important to use the correct base for each application. The standard range available is as follows:-

- i) **STB-4 Base:** having 4 terminals, for standard use with ST-P detector including the auxiliary output function.
- ii) **STB-4R Base:** having series resistor fitted (220,470 or 680 ohm) for use with ST-P detector including the auxiliary output function. The series resistor increases overall resistance of detector/base. This should not be used to power a remote indicator, the control panel needs to "see" the series resistor in order to distinguish between a short circuit fault and a fire alarm condition.

- iii) **STB-4SD:** This is identical to the standard STB-4 base, but also includes a schottky diode for head removal fault monitoring. The schottky diode is used in some fire systems to ensure power is maintained, in the event of an unauthorised detector head removal, to other detectors further on the zone.
- iv) **STB-4SDR:** This is identical to the STB-4R base, but also includes a series resistor.

Section 5 - INSTALLATION

In normal use, the ST-P detector will be installed at ceiling level. Pass the field wiring through the cable hole in the centre and from the rear of the base. Offer up and affix the base to the ceiling or conduit fitting with screws via the base mounting holes. Consider visibility and orientation of the detector's integral alarm LED indicator when mounting the base. Connect the field wiring to the base terminals, as detailed on page 7 making sure the wiring does not obstruct fitting of the detector head. Fit the detector head by inserting it into the base and turning clockwise until the notch in the detector rim aligns with base locking screw.

Fit the red plastic dust cover supplied over the detector to keep out dust etc, until the system is commissioned. If the dust cover is not fitted and the environment is slightly dusty, such as when building work is being completed, for example, problems of false alarms are likely to occur after commissioning unless cleaning of the detector is undertaken. At commissioning, the dust cover should be removed and discarded.

NOTE: THE RED PLASTIC DUST COVER MUST BE REMOVED FROM THE DETECTOR IN ORDER FOR THE DETECTOR TO FUNCTION CORRECTLY.



NITTAN

ST-P SENSORTEC
PHOTOELECTRIC SMOKE DETECTOR
INSTRUCTION MANUAL

No: NISM/STP/01	
DATE: SEPTEMBER 1995	
PAGE: 4 of 7	ISSUE: 01

Section 6 - MAINTENANCE AND CLEANING

Maintenance:

The ST-P detector is a high quality product engineered for reliability. In order to obtain optimum performance, periodic maintenance is required as a dirty detector is more likely to cause a false alarm.

Servicing:

Servicing of the system should be carried out in accordance with the requirements of BS 5839 Part 1, Fire Detection and Alarm Systems for Buildings: Code of Practice for System Design, Installation and Servicing.

The maintenance procedures described below should be conducted with the following frequency:

One month after installation:- Routine Inspection and every 3 months after.

Every 6 months:- Operational Test

Every 12 months:- Functional clean and Test

All above frequencies of maintenance are dependent on ambient conditions.

Routine Inspection

i) Ensure the detector head is secure and undamaged.

ii) Check the smoke entry apertures are in no way obstructed.

iii) Ensure the surface of the detector's outer cover is clean. If there are deposits due to the presence of oil vapour, dust etc, then the detector should be cleaned in accordance with the cleaning instructions detailed later in this manual. It may be advisable to ensure that such cleaning is conducted regularly in the future.

iv) Ensure no equipment which may generate combustion products or fine airborne particles, has been installed in the vicinity of the detector since the last routine inspection. If such equipment has been installed, then you should notify the Fire Safety Officer or other competent authority that its presence may cause false alarms.

Operational Test

The purpose of the Operational Test is to confirm the detector's correct operation in response to a smoke condition.

i) Take any necessary precautions at the control panel to limit the sounding of the alarm sounders/bells and any fire service summoning device.

ii) Introduce a discrete amount of smoke into the detector head, using NID-T2 Smoke Test Head or equivalent. Check that the detector gives an alarm condition within 15 seconds. Check the LED indicator on the ST-P detector illuminates and any remote indicator LED fitted also illuminates.

iii) After the detector has given the alarm condition, reset the detector from the control panel. It may be necessary to allow a short time to elapse before resetting the detector, to allow any residual smoke from the test, to disperse.

iv) Before proceeding to the next detector, ensure that the detector just tested, does not re-operate due to the presence of residual smoke.

Functional Test & Light Noise Tests:-

The Functional Test checks that the detector's internal circuitry operates correctly.

The Light Noise Test checks the condition of the ST-P's chamber by confirming if the detector requires cleaning. (Note: When the ST-P's were originally commissioned, each detector's reading should have been noted. Then, when any future testing/routine maintenance is carried out, the readings obtained from each detector could then subsequently be compared with the previous readings.)

These tests may only be carried out with the NID-ET5 Electronic Tester.

The ST-P detector may, however, be returned to our factory for testing.

Details of the Functional Test and Light Noise Test are given in the Instruction Manual NID-ET5, ref: NISM/ET5/01A.



NITTAN

ST-P SENSORTEC PHOTOELECTRIC SMOKE DETECTOR INSTRUCTION MANUAL

No: NISM/STP/01	
DATE: SEPTEMBER 1995	
PAGE: 5 of 7	ISSUE: 01

Cleaning

Figure 1:- 'Exploded' View of ST-P Detector Assembly

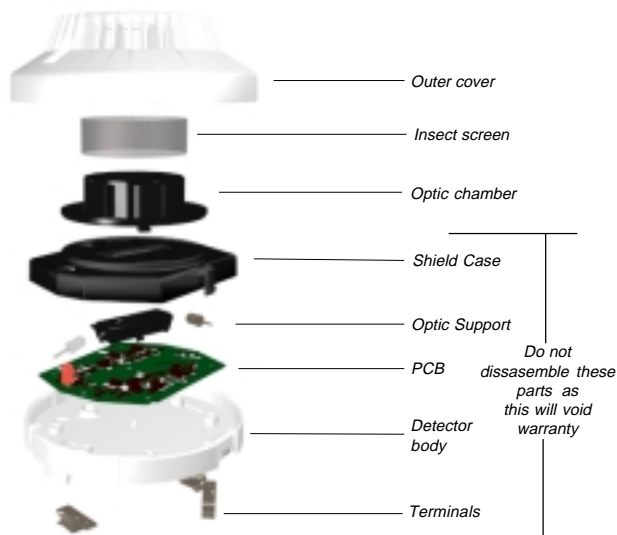

i) Carefully remove the outer cover of the detector by gently releasing the larger outer cover clip, (see figure 2 below), with a small screwdriver, this clip is visible from the rear of the ST-P detector. It is not necessary to use any excessive force.

Figure 2:- Rear view of ST-P Detector.

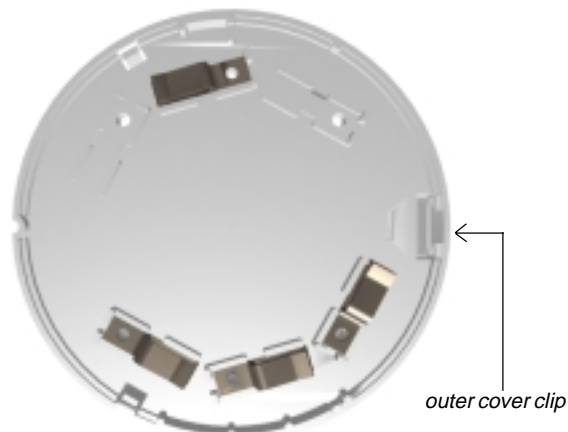

ii) Remove the chemically-etched insect screen.

iii) Remove the optic chamber by gently twisting in an anti-clockwise movement

DO NOT DISMANTLE ANY FURTHER

iv) Examine the optic chamber and the optic's bridge and check for any dust or dirt which may give cause for false alarm.

If the detector is very dirty, damaged or corroded please return the complete detector to Nittan for service.

v) If the parts of the detector are still serviceable, proceed to clean the outer shield case and plastic outer cover using both a clean dry brush for dry dust and dirt. A lint-free cloth moistened with alcohol may be used to remove sticky deposits from the insect screen, optic chamber and the optic's bridge.

vi) Reassemble the detector in the reverse order. Refit the plastic outer cover, aligning the LED indicator aperture with the LED indicator. Check alignment of the outer cover prior to fully pushing home in order to avoid distortion of the insect screen.

Make sure that the three securing clips of the outer cover are properly aligned and seated. 'Snap fit' the plastic outer cover to the ST-P body, taking care not to compress the insect screen.

vii) Conduct a Light Noise Test and Functional Test to confirm correct operation of the detector, this measurement should be observed after 20 seconds.

Ultrasonic Cleaning

This method may be used to good effect for the removal of contamination from the outer cover, plastic optic chamber, and chemically etched insect screen, only, after they have been dismantled from the detector. However, care must be taken in selection of the solvent so as not to cause damage to the plastic and insect screen. The solvent supplier should be consulted as to its suitability.

Under no circumstances should the fully assembled detector be cleaned without disassembly as this may cause damage to the special treatment applied to specific components within the detector.

**NITTAN**

ST-P SENSORTEC
PHOTOELECTRIC SMOKE DETECTOR
INSTRUCTION MANUAL

No: NISM/STP/01	
DATE: SEPTEMBER 1995	
PAGE: 6 of 7	ISSUE: 01

Section 7 - SPECIFICATION

- Model Reference:** - **ST-P**
Detector Type: Photoelectric smoke detector
- Sensitivity** - 3% Obscuration per metre
- Supply Voltage:** - 24V dc nominal (range 16V to 30V)
- Voltage Ripple:** - 20% maximum
- Alarm Voltage:** - 5V d.c.between +(terminal 3) and - (terminals 1,6) at 25 deg. C
- Monitoring Current:** - 40 μ A max. at 24V d.c.
- Alarm Current:** - 65 mA. max.
- Charging Time:** - 20 seconds
- Ambient Temperature Range:** - -10 deg.C to +50 deg.C

Note: The power supply/control equipment to the ST-I detector should limit the maximum current allowable to the detector in fire condition to 65mA. If the current is not limited then the detector will be damaged.

Section 8 - ENVIRONMENTAL PARAMETERS

Temperature Considerations:
Over the range from -10 deg. C. to +50 deg. C..

Humidity:
Relative Humidity of up to 90%, measured at 50 deg. C., non condensing.

Section 9 - EMC**Installation**

The installation shall be in accordance with the regulations either of the approval body for an approved system, or otherwise, to the national code of practice/regulations for the installation of the fire alarm system, e.g. BS 5839 part 1.

Electromagnetic Compatibility (EMC)

On a site where there is an unusually high level of potential electrical interference, e.g. where heavy currents are being switched or where high levels of R.F. are prevalent, care then must be taken in the type and routing of cables. Particular care should be given to the separation of zone wiring from the cable carrying the interference.



NITTAN

ST-P SENSORTEC
PHOTOELECTRIC SMOKE DETECTOR
INSTRUCTION MANUAL

No: NISM/STP/01	
DATE: SEPTEMBER 1995	
PAGE: 7 of 7	ISSUE: 01

Section 10 - CONNECTIONS (Also suitable for ST-I Photoelectric detector)

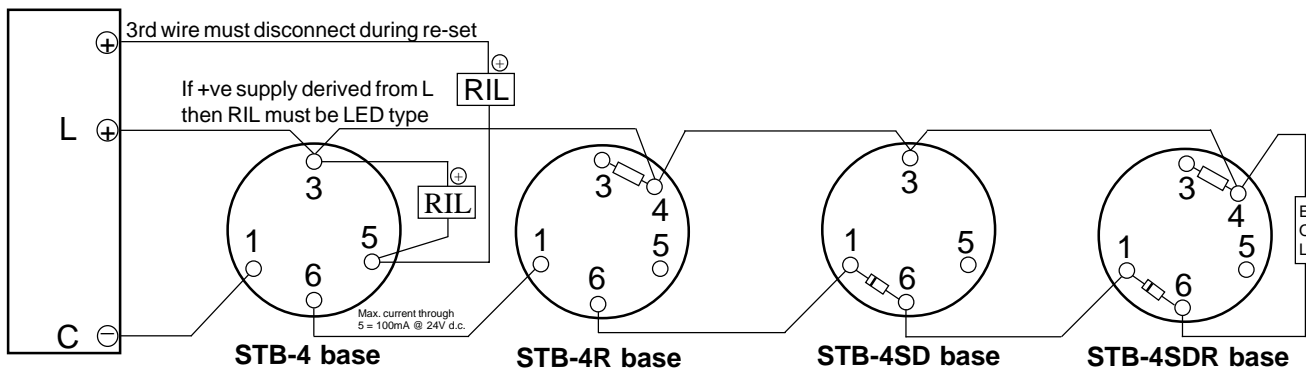

Section 11 - DIMENSIONS

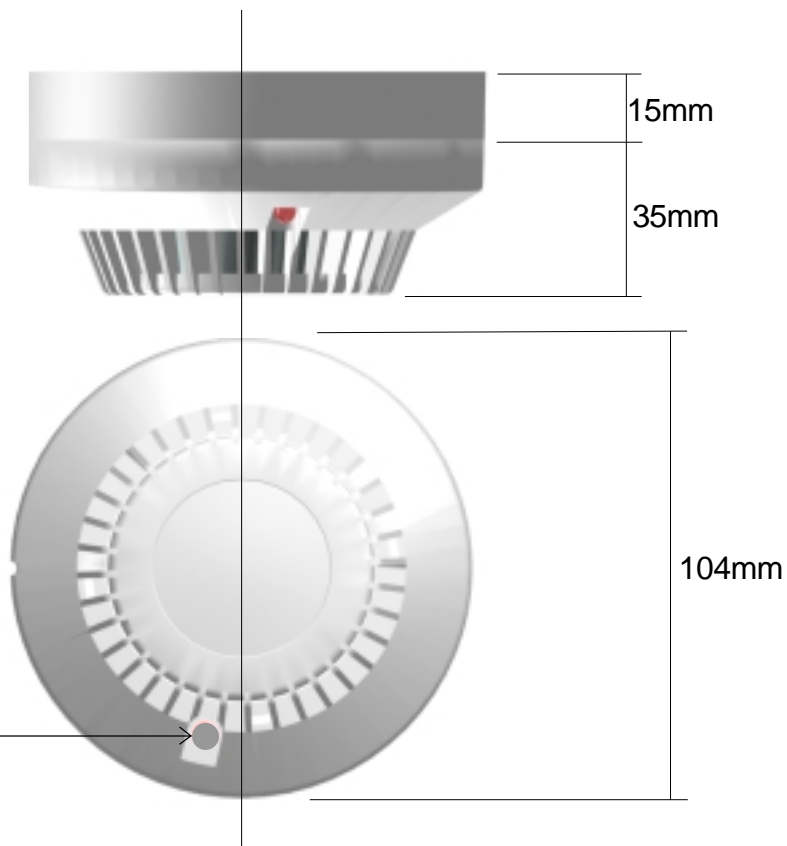

NOTE:
Clear LED: denotes
Photoelectric detector.

Manual End.

D:\MANUALS\STPMAN.PM5 August 1995.

REF: NISM/STP/01 version 01.

NITTAN (UK) LTD

Document No. NISM/STP/01
Date SEPT. 1996

From world leaders in **SENSOR TECHNOLOGY**
comes **SENSORTEC.....**

**INSTRUCTION MANUAL
FOR
SENSORTEC
ST-P
PHOTOELECTRIC
SMOKE DETECTOR**



Quality System Certificate No. 041
Assessed to BS EN ISO 9002



LPCB REF: 041c/06
&
LPCB REF: 367a/02



NITTAN (UK) LTD.
Hiple Street
Old Woking
Surrey
England
GU22 9LQ
United Kingdom

Tel: +44 (0) 1483 769555
Fax: +44 (0) 1483 756686